



DS-K

powerful › compact

PORTABLE COMPRESSORS



IDEAL
EQUIPMENT
FOR SERVICE
VEHICLES



- › Compact design, ideal for installation on service vehicles.
- › Uses the fuel tank and battery of the vehicle to save space.
- › Smallest footprint available.
- › Lowest weight available.
- › All filters readily accessible.
- › Spin-on type, for easier maintenance.
- › Easy to transport and to load / Palletized based.
- › Cooling fan on the engine axle.
- › Intuitive starter
Integrated hours counter
Manometer.
- › Thermostat with safety arrest
at high temperatures.
- › Airend with optimized profile,
max efficiency and operational
safety.
- › High efficiency trapezoidal
belt-drive, easy to supply
and overdimensioned
to ensure transmission
with less maintenance.



DS-K

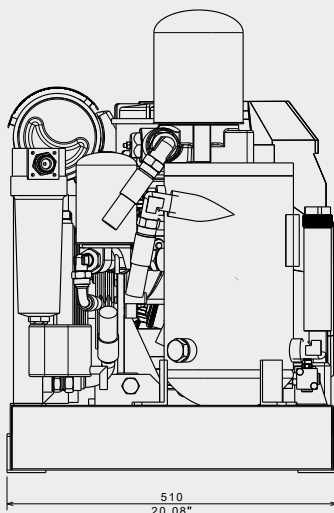
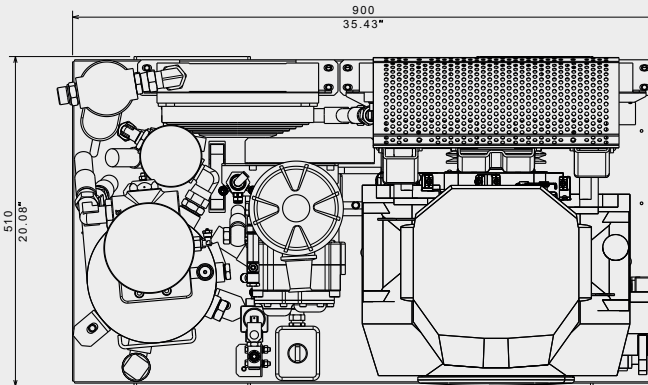
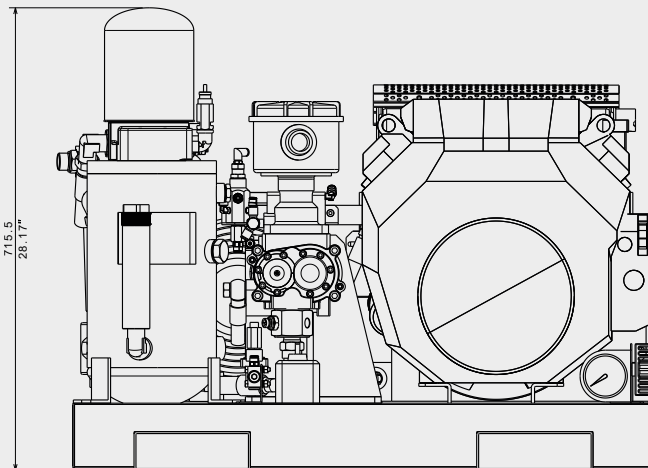

- › Fixed RPM
 - ↳ Less components
 - ↳ Easier layout
 - ↳ Highest reliability

› Start/stop "INTELLIGENT SYSTEM", exclusive from ROTAIR, to prevent the risk of incorrect procedures during specific functioning.

› Air/oil separator filter, highly oversized, to guarantee an excellent air/oil separation.

› Single stage oversized air filter for compressor part, to guarantee good filtering of the air intaken by airen.



THE RESPECT OF ORDINARY MAINTENANCE INTERVALS AND THE USE OF GENUINE SPARE PARTS ENSURE CONSTANT AND OPTIMAL PERFORMANCES AND RELIABLE DURABILITY THROUGH TIME.

Technical Data

weight ›

142 kg
313 lbs

COMPRESSOR

Operating pressure		10 bar - 145 psi
Free air delivery		1150 l/min - 40 cfm
Minimum working pressure		5,5 bar - 80 psi
Drive system engine-airend		Belt-drive XPZ oversized
Compressor cooling system		Air / Oil
Oil cooling capacity		5 lt / 1.1 UK gal
Air outlet temperature		20°C / 68°F + ambient temperature
Outlet valves		1 x 3/4"

PETROL ENGINE

Engine make		HONDA
Engine type		GX 630
Engine system		4 strokes
Emissions		Stage V
Displacement		690 cc
N. cylinders		2
Aspiration		Natural
Max engine power @2500 RPM		15.5 kW-20.8 HP
Fixed engine speed		2500 RPM
Cooling system		Air
Lubrication system capacity		1,9 lt / 0.42 UK gal

ENVIRONMENTAL CONDITIONS

Max ambient temperature		50°C - 122°F
Max altitude		1800 m a.s.l.
Min working temperature		-10°C / 14°F

powerful › compact

PORTABLE COMPRESSORS



•All images and pictures are indicative. Data can be changed without prior notice.





powerful > compact

PORTABLE COMPRESSORS

TO EQUIP
SERVICE
VEHICLES

GOMMAIR
DS
DS-K

DS-K | 09.2021 - Rev.01

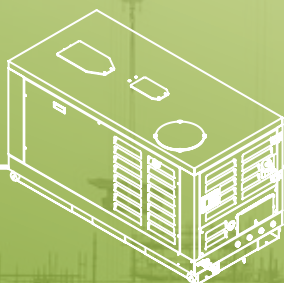

ROTAIR TECHNOLOGY AND
ENGINEERING SOLUTIONS

Via Bernezzo, 67 - 12023 Caraglio (Cn) - ITALY
Tel: +39 0171.619676 / Fax: +39 0171.619677
www.rotairspa.com | info@rotairspa.com



Azienda
certificata
ISO
9001:2008

ISO 9001
BUREAU VERITAS
Certification

