

# GGW85G

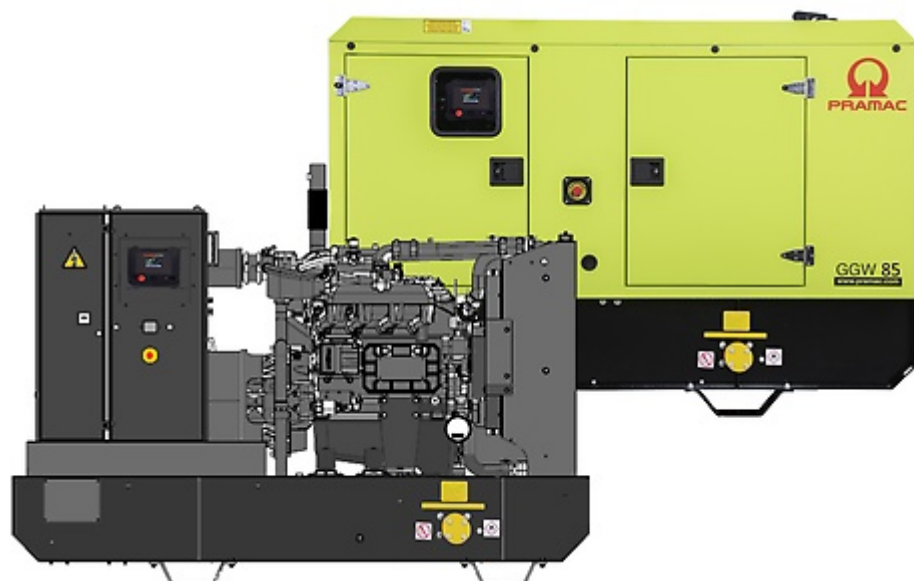

## Main Features

Frequency	Hz	50
Voltage	V	400/230
Power factor	cos $\phi$	0.8
Phase		3
Fuel		Natural Gas



## Power Rating

Emergency Standby Power ESP	kVA	85
Emergency Standby Power ESP	kW	68









## Designed to the following standards:

Ratings definition according to standard ISO8528 1:2005 normative 1000mbar, 25°C, 30% relative humidity.

### ESP - Emergency Standby Power:

It is the maximum power available during a variable electrical power sequence, under the stated operating conditions, for which a generating set is capable of delivering in the event of a utility power outage or under test conditions for up to 200 h of operation per year with the maintenance intervals and procedures being carried out as prescribed by the manufacturers. The permissible average power output over 24 h of operation shall not exceed 70 % of the ESP.

	BS 5514 and 6271
	SAE J1349
	NFPA 37, 70, 99, 110
	NEC 700, 701, 702, 708
	ISO 3046, 7637, 8528, 9001
	NEMA ICS10, MG1, 250, ICS6, AB1
	ANSI C62.41



### Engine specifications

Engine Brand	Generac	
Nr. of cylinder and disposition	4 in line	
Displacement	cm <sup>3</sup>	4450
Bore	mm	114.3
Stroke	mm	107.95
Compression Ratio	9.1:1	
Aspiration	Turbocharged	
Operating Speed-Nominal	rpm	1500
Frequency Regulation (steady state)	% (+/-)	1
Fuel	Natural Gas	
Ignition	Electronic	
Fuel consumption 75% ESP	kg/hr	14.1
Fuel consumption 100% ESP	kg/hr	17.9
Operating Fuel Pressure	kPa	1.7-3.5
Engine cooling system	Water	
Cooling fan	Type	Mechanical
Coolant capacity	l	14.5
Electric circuit	V	12

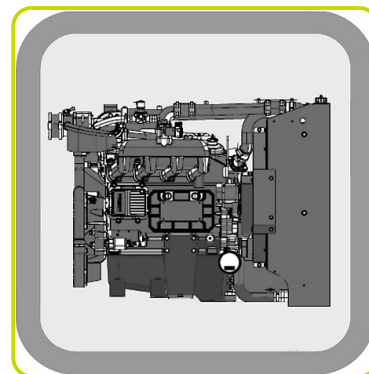

### Alternator Specifications

Alternator	Mecc Alte	
Model	ECP 32-2L/4 C	
Poles	4	
Class	H	
Type	Brushless	
Standard AVR	DSR	
Voltage tolerance	%	1
IP protection	23	
Voltage regulation system	Electronic	



### Fuel Consumption Rates

Fuel type	Natural Gas	
Fuel consumption 25% ESP	sm <sup>3</sup> /hr	8.8
Fuel consumption 50% ESP	sm <sup>3</sup> /hr	14.0
Fuel consumption 75% ESP	sm <sup>3</sup> /hr	19.3
Fuel consumption 100% ESP	sm <sup>3</sup> /hr	24.5
Refence gas with density of 0.73 kg/smc and HHV=37.6 MJ/smc		



## STANDARD FEATURES

### ENGINE SYSTEM

- Oil Drain Extension
- Heavy Duty Air Cleaner
- Fan Guard
- Stainless Steel Flexible Exhaust Connection
- Factory-Filled Oil And Coolant

### Fuel System

- Primary And Secondary Fuel Shutoff
- Flanged Fuel Line Connection DN32 PN6
- Electronic pressure regulator with automatic Air-Fuel ratio control
- Stoichiometric combustion (rich-burn) with engine exhaust lambda-sensor

### Cooling System

- Close Coolant Recovery System
- UV/Ozone resistant hoses
- Factory Installed Radiator
- 50/50 Ethylene Glycol Antifreeze
- Radiator Drain Extension

### Electrical System

- Battery Charging Alternator
- Battery Cables
- Battery Tray
- Rubber-Booted Engine Electrical Connections
- Solenoid Activated Starter Motor
- Ignition coils rack-mounted
- GENERAC Electronic fuel ignition (EFI) module

### ALTERNATOR SYSTEM

- Class H Insulation Material
- 2/3 Pitch
- Skewed Stator
- Auxiliary Winding Excitation System
- Sealed Bearing
- Amortisseur Winding
- Full-Load Capacity Alternator

### GENERATOR SET

- Internal Genset Vibration Isolation
- Wrapped Exhaust Piping (Enclosed Only)
- Bottom (floor) power cable outlet
- Exhaust silencer Mounted in the Discharge Hood (Enclosed Sets)

### ENCLOSURE (if selected)

- High-Performance Sound Absorbing Material
- Gasketed Doors
- Galvanized Sheet Metal Construction
- Upward Facing Discharge Hood (exhaust)
- Steel Hinges

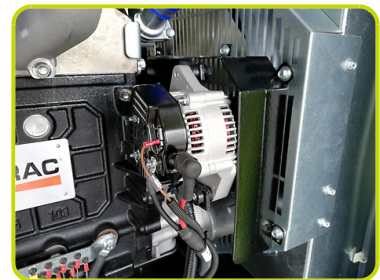
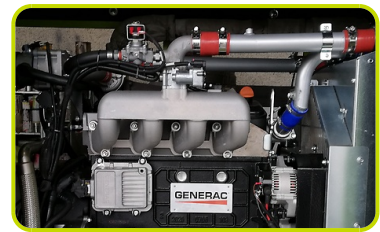

## CONTROL SYSTEM

### Power Zone® Pro Controller

Advanced integrated gen-set control platform that includes all drives and functions to manage the gas gen-set and perform an optimal combustion of the fuel, while maximizing performance.

### Program Functions

- NFPA 110 Level 1 Compliant
- Engine Protective Functions
- Alternator Protective Functions
- Digital Engine Governor Control
- Programmable Inputs and Outputs
- Remote Display Capability
- Remote Communication via Modbus® RTU, Modbus TCP/IP, and Ethernet 10/100
- Alarm and Event Logging with Real Time Stamping
- Expandable Analog and Digital Inputs and Outputs
- Remote Wireless Software Update Capable
- BMS, and Remote Telemetry
- Built-In Programmable Logic Eliminates the Need for External Controllers Under Most Conditions
- Programmable I/O Channel Properties
- Built-In Diagnostics

### Alarms and Warning

- High/Low Oil Pressure
- High/Low Coolant Level
- High/Low Coolant Temperature
- Sender/Sensor Failure
- High/Low Oil Temperature
- Over Total kW
- Over/Under Speed
- Over/Under Voltage
- Over/Under Frequency
- Over Current
- High/Low Battery Voltage
- Battery Charger Current
- Phase to Phase and Phase to Neutral Short Circuits (I2T Algorithm)

### 4.3 Inch Color Touch Screen Display

- Resistive Color Touch Screen
- Easily Identifiable Icons
- Multi-Lingual
- On Screen Editable Parameters
- Key Function Monitoring
- Three Phase Voltage, Amperage, kW, kVA, and kVAR
- Frequency
- Engine Speed
- Engine Coolant Temperature
- Engine Oil Pressure
- Engine Oil Temperature
- Battery Voltage
- Hourmeter
- Warning and Alarm Indication
- Diagnostics
- Maintenance Events/Information

### Other Protections

- Circuit Breaker (III poles)
- Emergency stop button



### Installation data

Total air flow	m <sup>3</sup> /min	121.80
Exhaust gas flow	m <sup>3</sup> /min	10.3
Exhaust gas temperature	°C	740
Max exhaust backpressure	mbar	100



### Electrical Data

Battery capacity	Ah	100
Nominal current	A	NaN
Max current	A	126.26
Circuit breaker	A	125

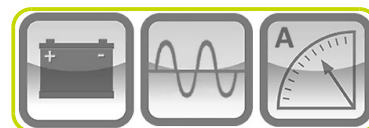

### OPEN VERSION

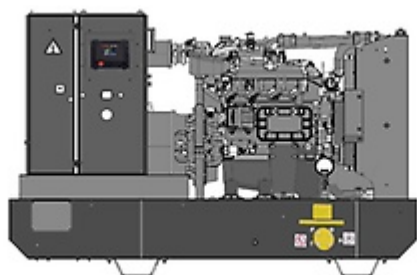

### Dimensional data

Length	(L) mm	2270
Width	(W) mm	1100
Height	(H) mm	1490
Weight	kg	994

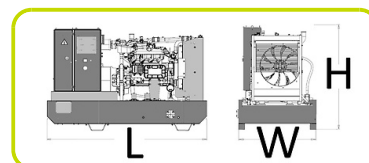

### CANOPY VERSION



### Dimensional data Canopy Version

Length	(L) mm	2760
Width	(W) mm	1130
Height	(H) mm	1810
Weight	kg	1349

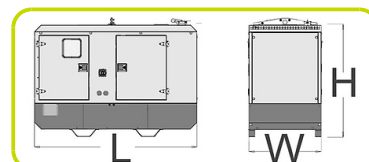

### Noise Level

Guaranteed noise level (LWA)	dB(A)	96
Noise pressure level @ 1 m	dB(A)	78
Noise pressure level @ 7 m	dB(A)	67



## OPTIONAL FEATURES

To be ordered with equipment (when necessary) :

### GENSET EQUIPMENT

Coolant Pre-Heating System (convection type)	PHS
3-Way catalytic muffler	CAT
Upsized Alternator	UAL
Alternator anti-condensation heater	ACH
Permanent Magnet Generator on alternator	PMG
Genset Metal Nameplate	GMN
Without Batteries	WBAT
Automatic Lube Oil Top Up System with lube oil tank	ALS
Different Canopy Colour	DCC

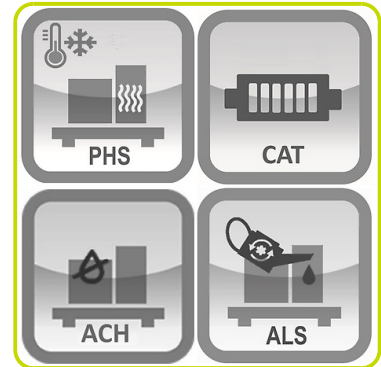

### CONTROL PANEL

Four poles circuit breaker	TIF
Auxiliary Contact for remote signalization	TLP
Remote Connection kit with Antenna	RCG

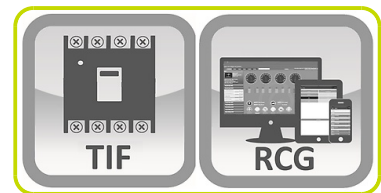

## Accessories

Items available as accessory equipment	:
ATS - Automatic Transfer Switch	ATS

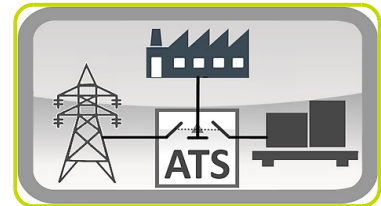

The information is aligned with the Data file at the time of download. Printed on 09/05/2023 (ID 16119)

©2023 | PR INDUSTRIAL s.r.l. | All rights reserved | Image shown may not reflect actual package. Specifications subject to change without notice